

CD AUTO CHANGER

KDC-C665/Y

SERVICE MANUAL

KENWOOD

© 1999-12 PRINTED IN JAPAN
B51-7554-00(S) 3444

When transporting these models, always attach CAUTION CARD and STEPPED SCREW (for transportation).

CAUTION CARD :B58-1275-04
STEPPED SCREW :N09-4186-25

Service jig	Parts No.
For initial position setting	W05-0635-00

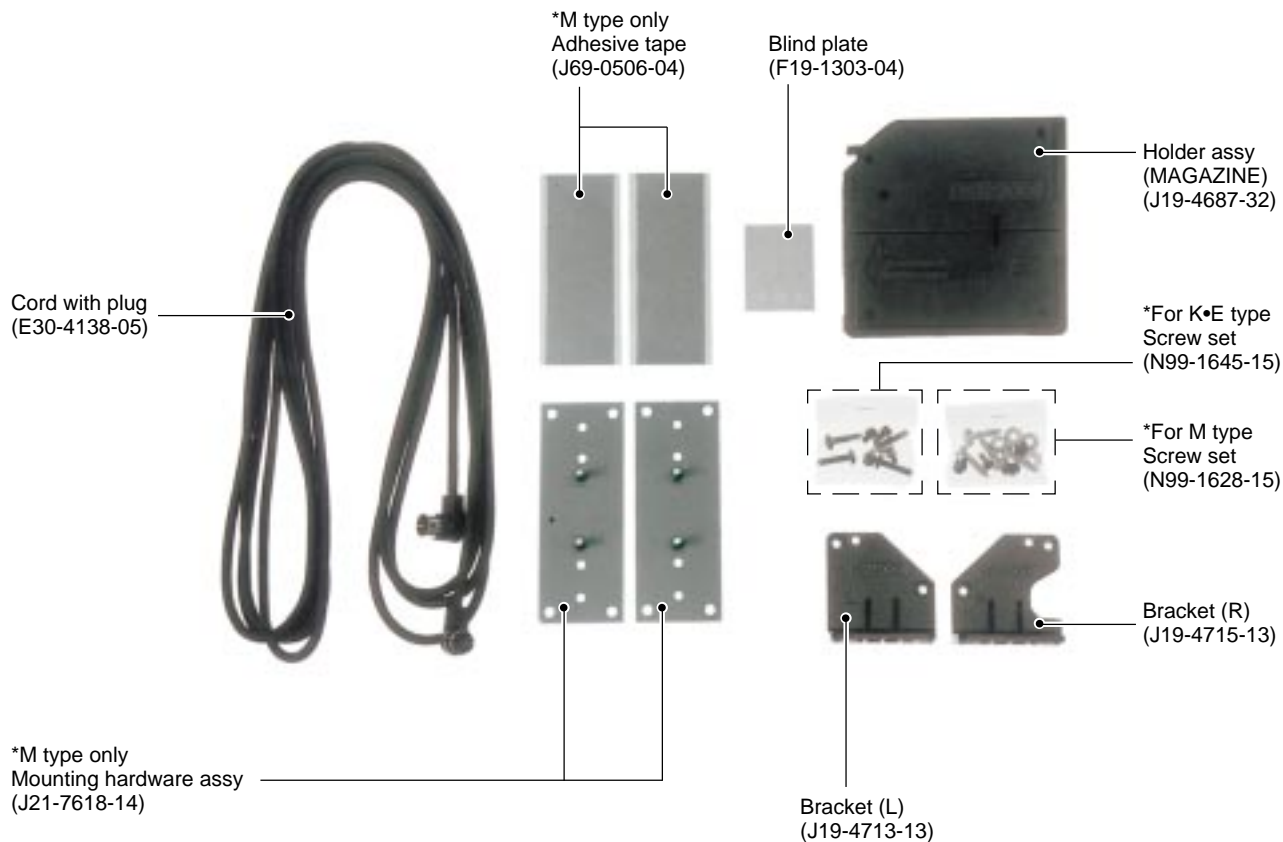
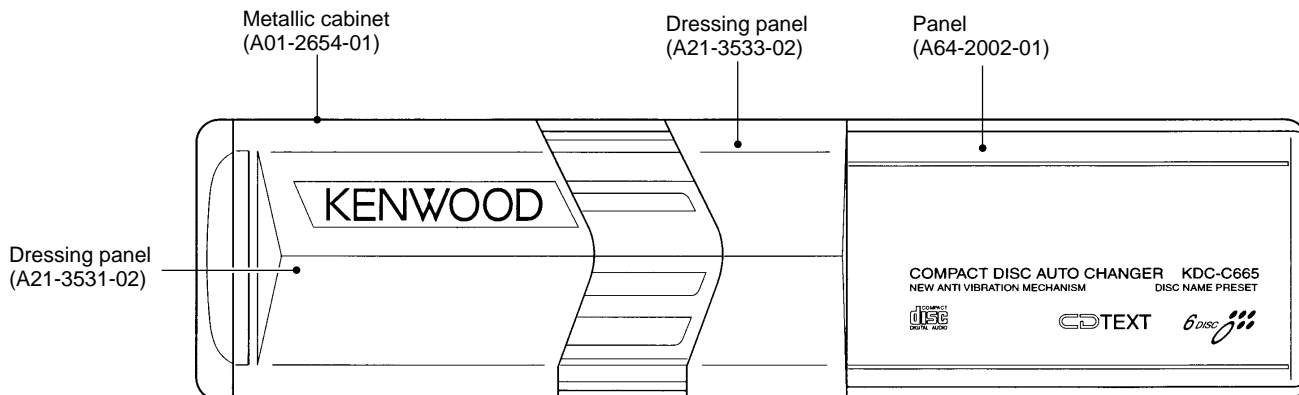

The MECHANISM OPERATION DESCRIPTION is same as model KDC-C660. Please refer to the service manual of model KDC-C660 (B51-7105-00).



KDC-C665/Y

BLOCK DIAGRAM

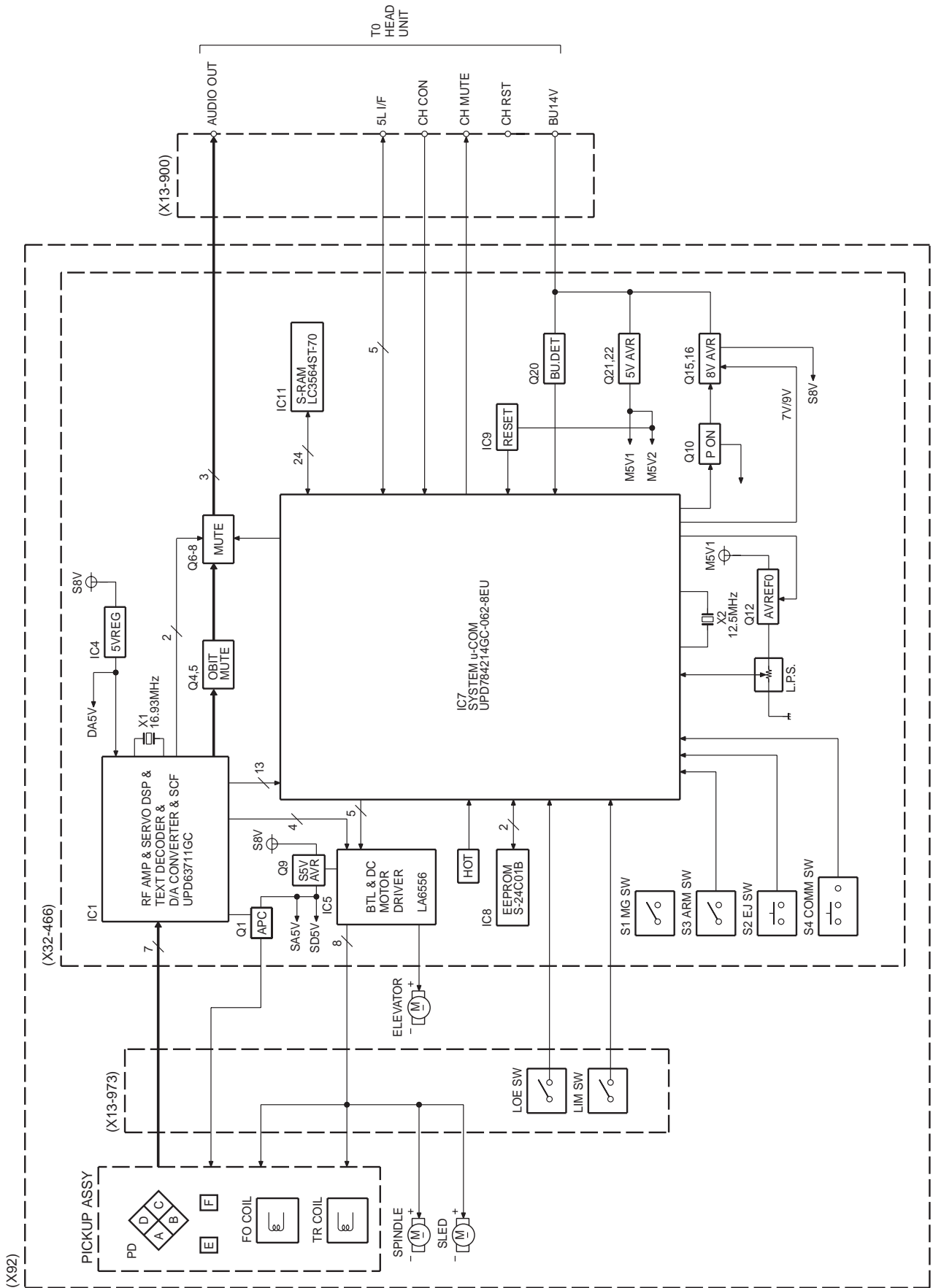

MICROCOMPUTER'S DESCRIPTION

System μ -com : UPD784214GC (X32- : IC7)

●Terminal description

Pin No.	Pin Name	I/O	Description
1	TOUT	O	Test output.
2	TSTB	O	Text data strobe signal.
3	-	O	NC.
4	FOK	I	H: Focusing OK. L: Focusing NG.
5	X OFF	O	H: Servo IC oscillation OFF.
6	RST	O	L: Servo IC reset.
7	AO	O	H: Parameter setting. L: Address register setting.
8	STB	O	L: Data latch.
9	VDD		Power supply connection.
10	X2	-	Oscillator.
11	X1	I	Oscillator.
12	VSS	I	GND.
13	XT2	-	NC.
14	XT1		GND.
15	RESET	I	L: Reset.
16	BSY		
17	MGSW	I	H: Holder IN. L: Holder OUT.
18	EJSW	I	H: Eject.
19	COMMSW	I	H: New. L: Old.
20	PACK	I	Text data pack sync signal.
21	CHCON	I	Changer control.
22	BUDET	I	B-U detection.
23	AVDD	I	A/D converter power supply.
24	AVREF	I	A/D converter reference voltage.
25	HOT	I	High temperature detection.
26	LPS	I	Position detection.
27	LOESW	I	L: Loading completed.
28	LIMSW	I	L: PU limit switch ON.
29	TOFF	I	Tracking off mode.
30	ADJSEL	I	H: Servo Adjustment OFF. L: Servo Adjustment ON.
31	TBANK	I	H: Gain UP. L: Normal.
32	SIM3		
33	AVSS		GND.
34	LPSCO	O	A/D converter power supply. H: OFF.
35	AMUTE	O	L: Muting ON.
36	AVREF1		A/D converter power supply.
37	SDI	I	Servo data input.
38	SDO	O	Servo data output.
39	SCK	O	Servo clock output.
40	DATAH	I	Data input from H/U.
41	DATAC	O	Data output to H/U.
42	HCLK	I/O	H: Clock input. L: Clock output.

Pin No.	Pin Name	I/O	Description
43	REQC	O	Communication request to H/U.
44	CHMUTE	O	L: Muting ON.
45	TSO	O	Text data output.
46	TSI	I	Text data input.
47	TSCK	O	Text clock output.
48~55	A0~A7	O	S-RAM address setting.
56~63	D0~D7	I/O	S-RAM data input/output.
64~68	A8~A12	O	S-RAM address setting.
69~71	A13~A15	O	S-RAM enable control.
72	VSS		GND.
73, 74	A16, A17	O	S-RAM enable control.
75	RAMOK	O	H: OK.
76	ELVADJ	I	L: Adjustment mode.
77	RD	O	S-RAM read control.
78	WR	O	S-RAM write control.
79	WAIT	I	Wait during S-RAM access.
80	ASTB	O	NC.
81	VDD		Power supply connection.
82	RAMTEST	I	H: S-RAM check mode.
83	REQH	I	Communication request from H/U.
84	SP/LO+	O	Spindle/Loading + control.
85	SP/LO-	O	Spindle/Loading - control.
86	ELV+	O	Mechanism UP/DOWN control.
87	ELV-	O	Mechanism UP/DOWN control.
88	SIM1	I	L: Text. H: No Text.
89	SEARCH	O	H: Play. L: Search.
90, 91	TEST1, 2	I	L: Normal. H: Test.
92	8V/7V	O	H: 7 V. L: 8 V (Servo power supply).
93	SLG	I	H: +3 dB. L: 0 dB (Sled gain).
94	TEST/VPP	I	L: Flash ROM program mode OFF.
95	SRVSEL	I	H: Servo mode.
96	SLNSA	I	L: Sled non-sensible area ON.
97	SDA	I/O	EEPROM data input/output.
98	SCL	O	EEPROM clock output.
99	PON	O	L: Power ON.
100	ARMSW	I	H: Arm switch ON.

KDC-C665/Y

ADJUSTMENT

LPS initial position adjustment procedure

Connect the changer to the H/U. While holding the magazine eject button of the changer, press the reset button of the H/U and, in about 1 second, release the magazine eject button. Press the CD button of the H/U to enter the **E-88** mode. Move the mechanism deck to around the 1st stage by pressing the **DISC-** or **DISC+** button.

Insert the adjustment tool into the tool hole on the changer mechanism. Then press the **DISC+** button to move the mechanism deck until the mechanism's slider hits the adjustment tool. When the motor locks (stops) press the **REPEAT** key of the H/U.

When the **REPEAT** key is pressed, the mechanism moves automatically to the 1st stage and the initial position adjustment completes. (The data is written in the E2PROM at this time.)

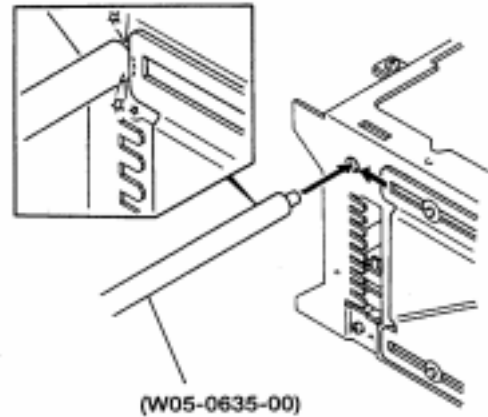

PC BOARD (Component Side View)

CD PLAYER UNIT (X32-4660-00)

X32-4660-00/4670-00 (J74-0966-01)

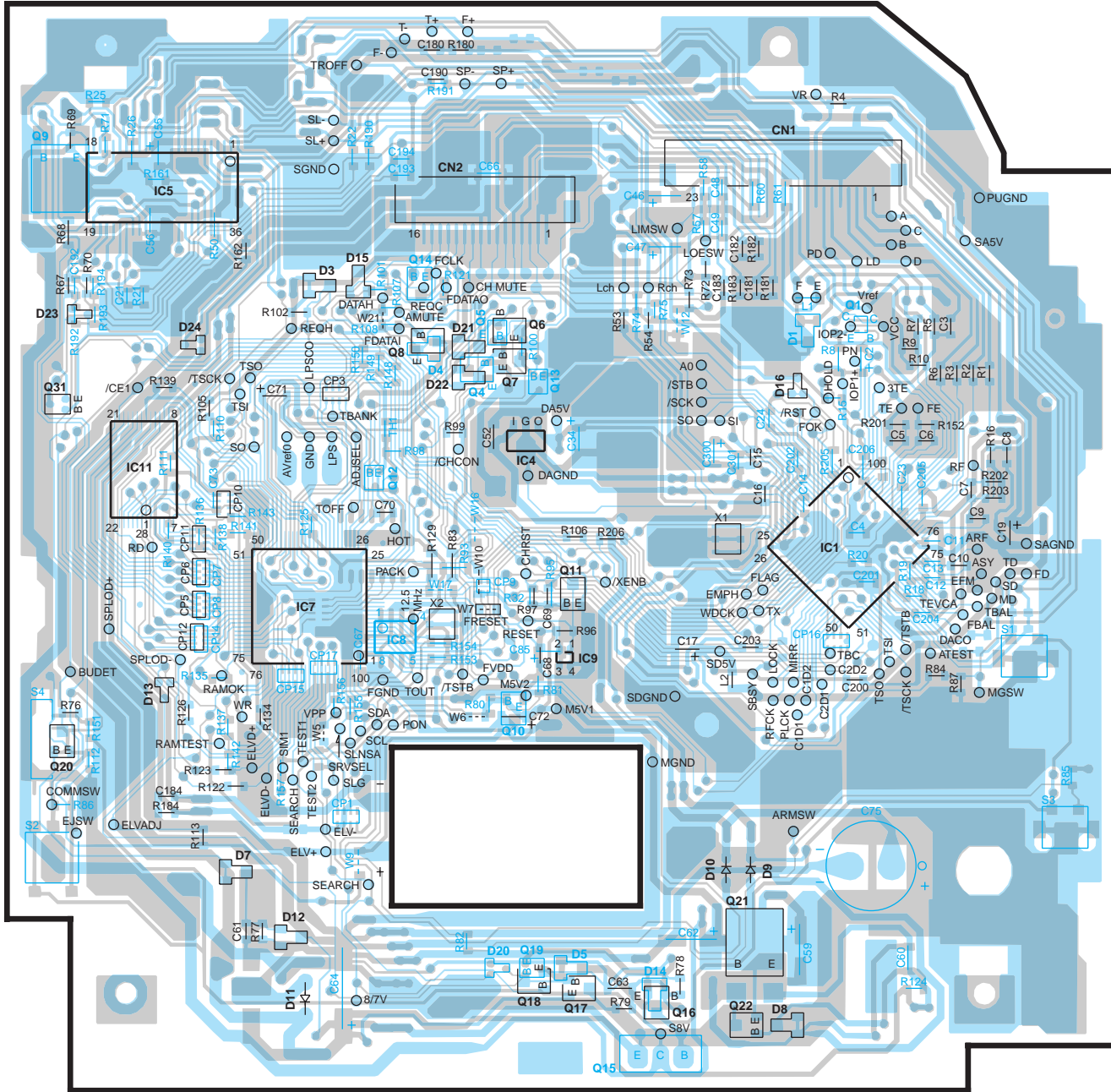

Refer to the schematic diagram for the values of resistors and capacitors.

SUB-CIRCUIT UNIT (X13-9730-00)

X13-9730-00/9740-00 (J74-0987-01)

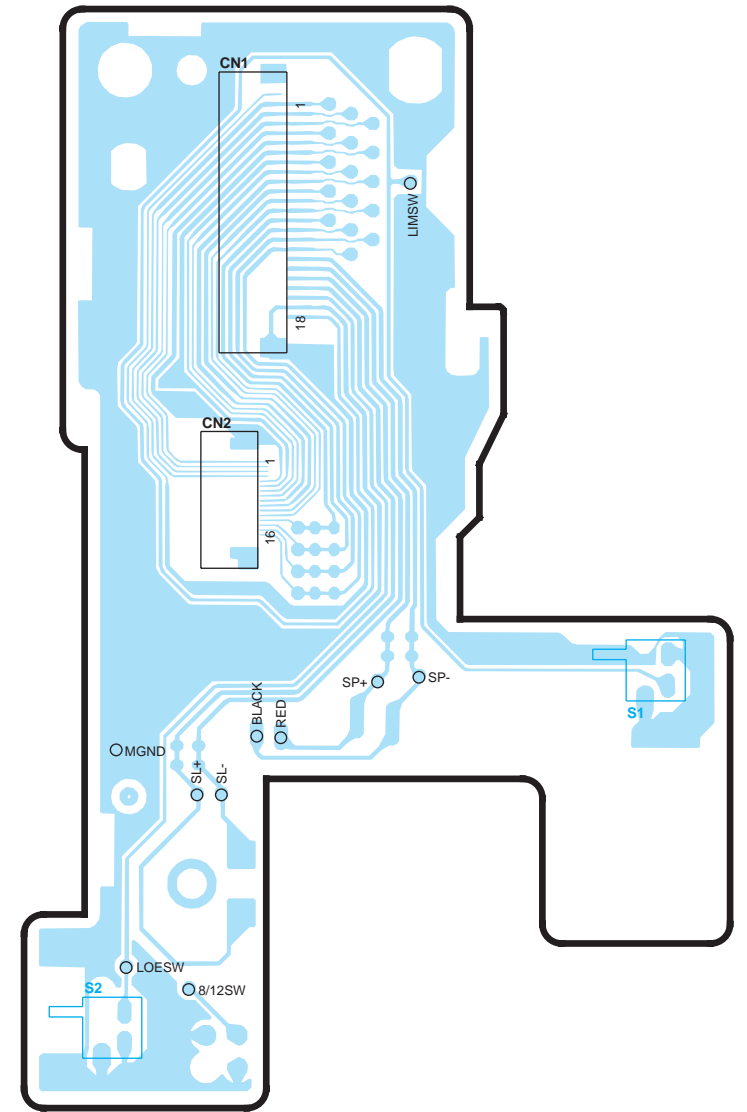

CD PLAYER UNIT (X32-4660-00)

Ref. NO.	IC	Q	Address
1			4D
4			4C
5			3A
7			4B
8			4B
9			4C
11			4A
	1		3D
	4		3C
	5		3C
	6		3C
	7		3C
	8		3C
	9		3A
	10		5C
	11		4C
	12		4B
	13		3C
	14		3B
	16		6C
	17		6C
	18		6C
	19		6C
	20		5A
	21		6D
	22		6D
	31		3A

SUB-CIRCUIT UNIT (X13-9000-00)

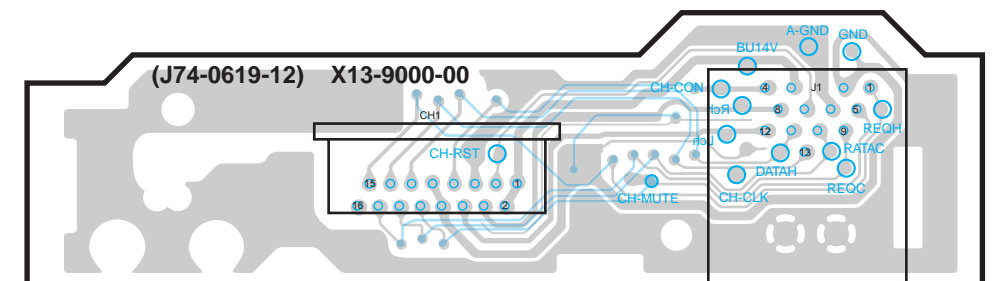

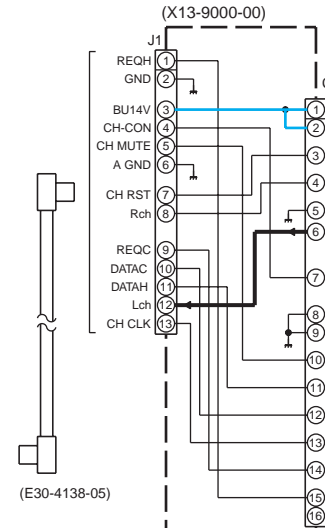
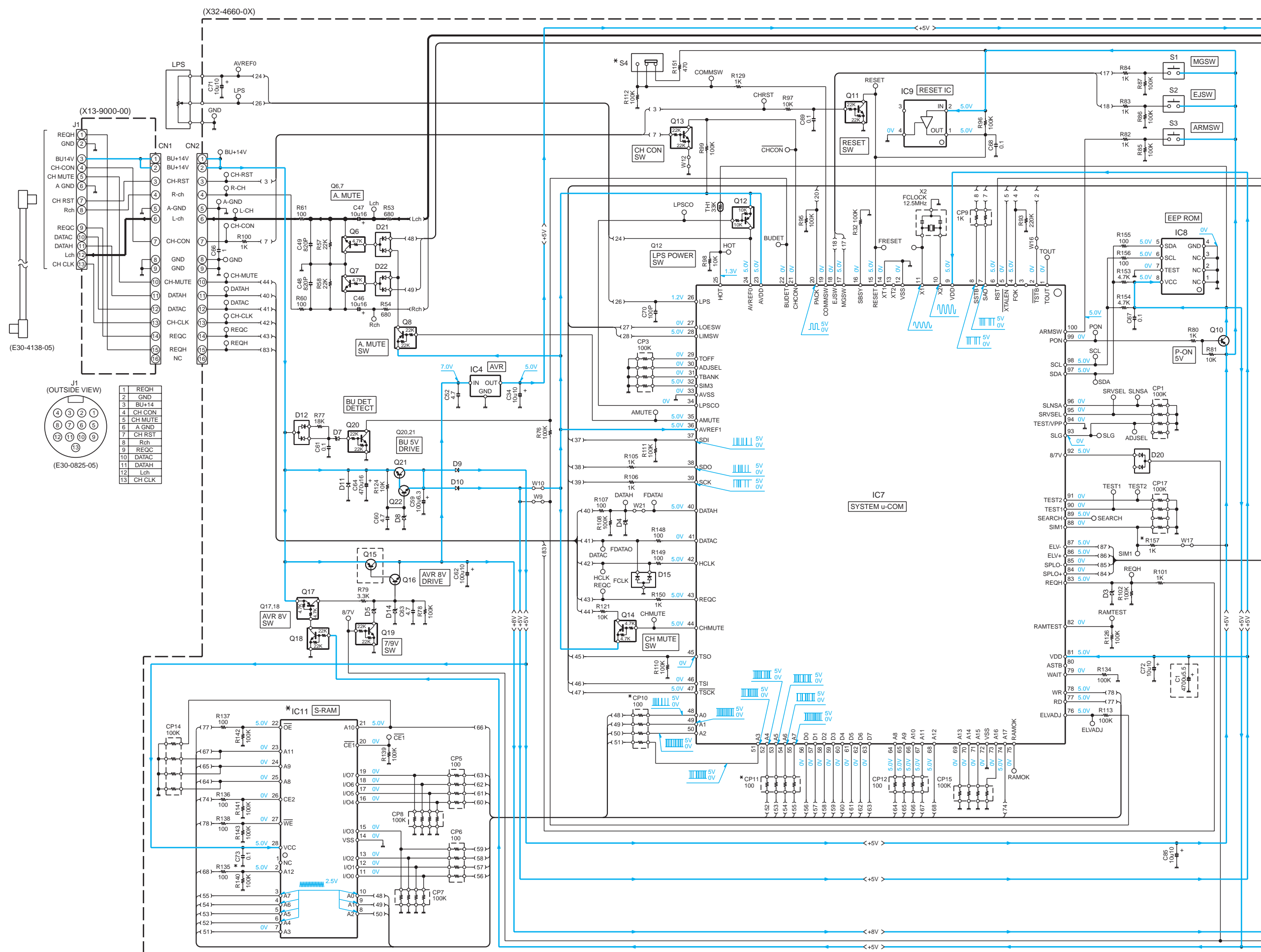

J1 (OUTSIDE VIEW)
(E30-0825-05)

1	REQH
2	GND
3	BU+14
4	CH-CON
5	CH-MUTE
6	A-GND
7	CH-RST
8	Rch
9	REQC
10	DATA
11	DATA
12	Lch
13	CH-CLK

1

2

3

4

5

6

7

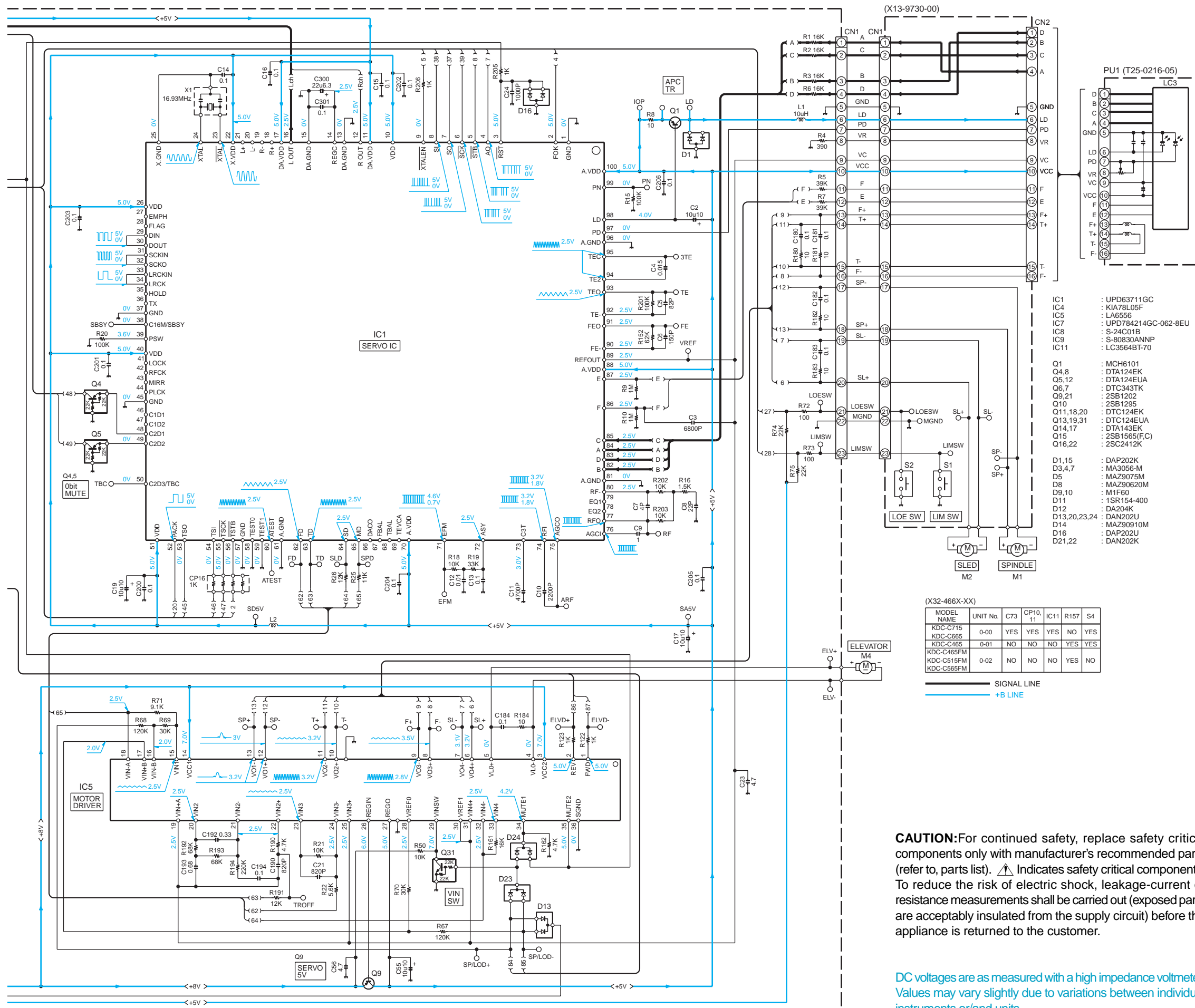

- IC1 : UPD63711GC
 - IC4 : KIA78L05F
 - IC5 : LA6556
 - IC7 : UPD784214GC-062-8EU
 - IC8 : S-24C01B
 - IC9 : S-80830ANNP
 - IC11 : LC3564BT-70
-
- Q1 : MCH6101
 - Q4,8 : DTA124EK
 - Q5,12 : DTA124EUA
 - Q6,7 : DTC343TK
 - Q9,21 : 2SB1202
 - Q10 : 2SB1295
 - Q11,18,20 : DTC124EK
 - Q13,19,31 : DTC124EUA
 - Q14,17 : DTA143EK
 - Q15 : 2SB1565(F,C)
 - Q16,22 : 2SC2412K
-
- D1,15 : DAP202K
 - D3,4,7 : MA3056-M
 - D5 : MAZ9075M
 - D8 : MAZ90620M
 - D9,10 : M1F60
 - D11 : 1SR154-400
 - D12 : DA204K
 - D13,20,23,24 : DAN202U
 - D14 : MAZ90910M
 - D16 : DAP202U
 - D21,22 : DAN202K

(X32-466X-XX)

MODEL NAME	UNIT No.	C73	CP10, 11	IC11	R157	S4
KDC-C715	0-00	YES	YES	YES	NO	YES
KDC-C665	0-01	NO	NO	NO	YES	YES
KDC-C465FM	0-02	NO	NO	NO	YES	NO

— SIGNAL LINE
 — +B LINE

CAUTION:For continued safety, replace safety critical components only with manufacturer's recommended parts (refer to, parts list). ⚠ Indicates safety critical components. To reduce the risk of electric shock, leakage-current or resistance measurements shall be carried out (exposed parts are acceptably insulated from the supply circuit) before the appliance is returned to the customer.

DC voltages are as measured with a high impedance voltmeter. Values may vary slightly due to variations between individual instruments or/and units.

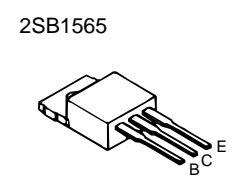

- DTA124EK
- DTA143EK
- DTC124EK
- DTC343TK
- 2SB1295
- 2SC2412K

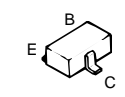

- DTA124EUA
- DTC124EUA

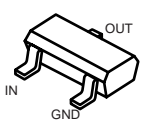

- DAN202K
- DAN202U

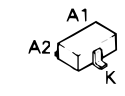

- DAP202K
- DAP202U
- DA204K

KDC-C665/Y

EXPLODED VIEW (MECHANISM)

- | | | | |
|---|------------------|---|-------------|
| A | M2x3.5 | : | N09-4126-05 |
| B | M2x2.5 (BLK) | : | N09-4228-05 |
| C | M2x5 | : | N86-2005-46 |
| D | M1.7x1.5 (BLK) | : | N09-4189-05 |
| E | φ 2x6 | : | N09-4154-05 |
| F | M1.7x3 | : | N09-4181-05 |
| G | M1.7x2.2 | : | N39-1722-46 |
| J | φ 1.55x3.8WASHER | : | N19-2105-04 |
| K | φ 1.6x4 WASHER | : | N19-2058-04 |
| L | φ 2x5 WASHER | : | N19-2080-04 |
| M | φ 1.6x3.5 WASHER | : | N19-2028-04 |

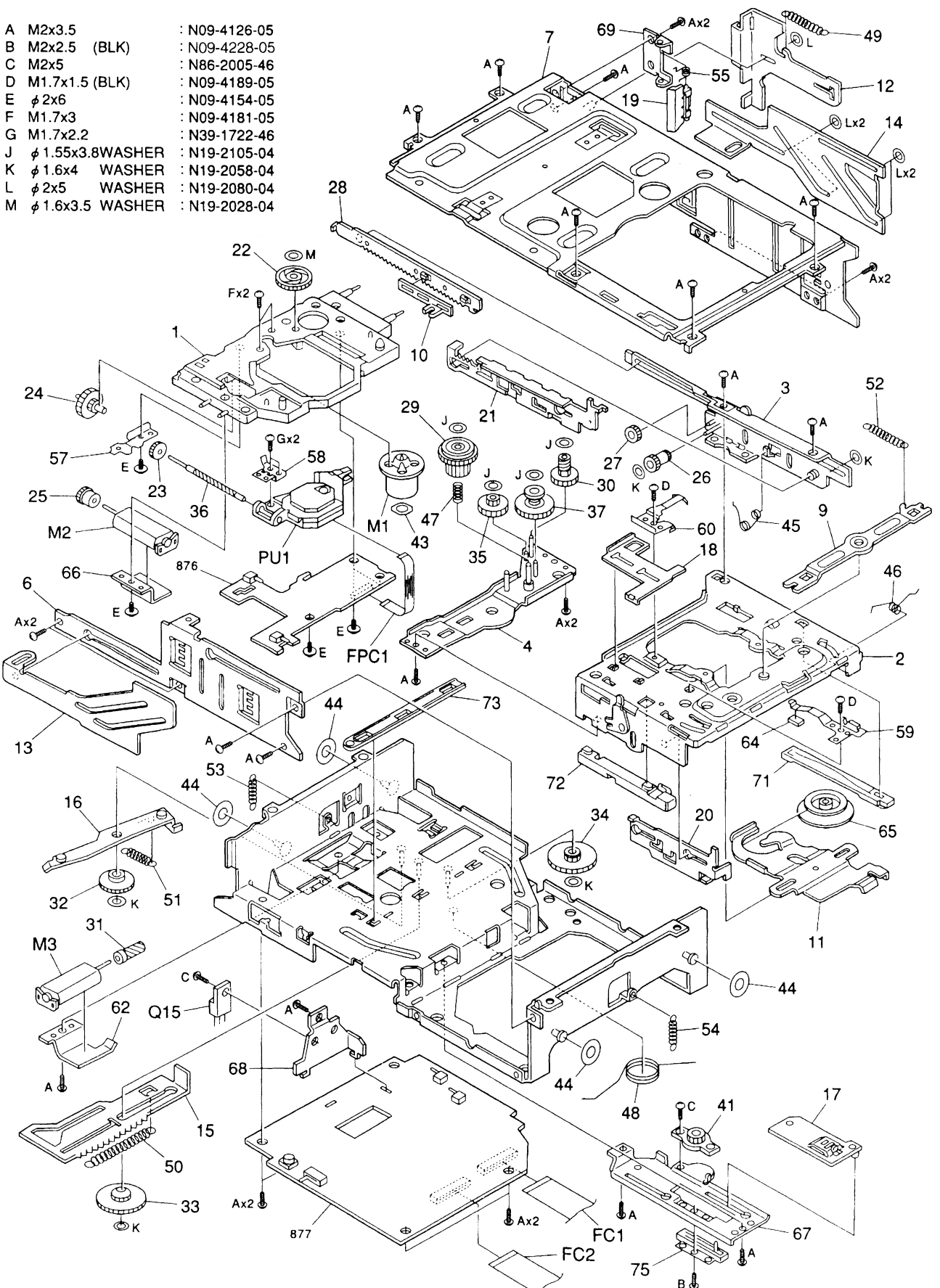

Parts with exploded numbers larger than 700 are not supplied.

KDC-C665/Y

EXPLODED VIEW (UNIT)

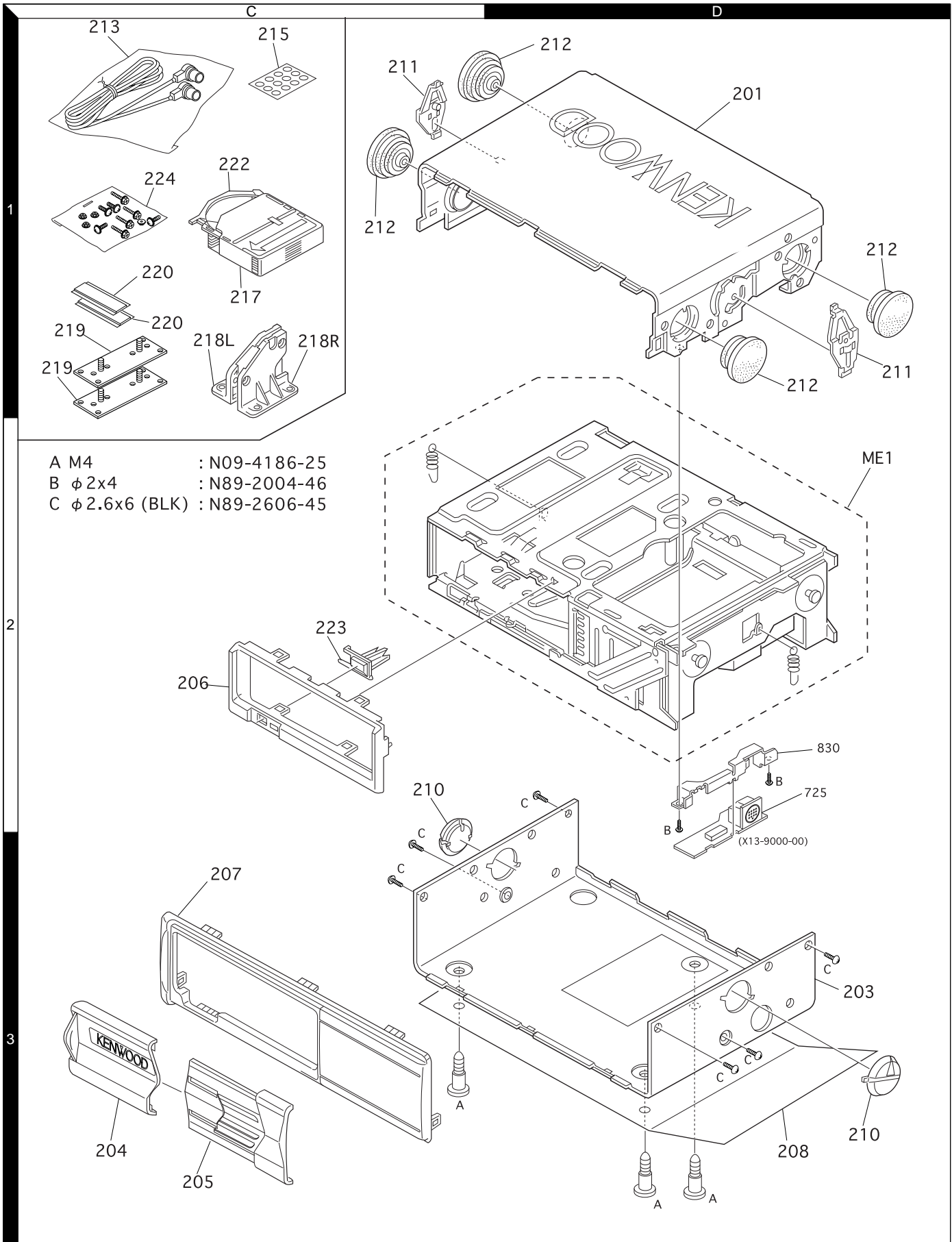

PARTS LIST

* New Parts

Parts without Parts No. are not supplied.

Les articles non mentionnes dans le Parts No. ne sont pas fournis.

Teile ohne Parts No. werden nicht geliefert.

KDC-C665/Y

SUB CIRCUIT UNIT(X13-9000-00)

SUB CIRCUIT UNIT(X13-9730-00)

CD PLAYER UNIT(X32-4660-00)

Ref.No.	A d d	N e w	Parts No.	Description	Dest inati on
KDC-C665/Y					
201	1D		A01-2654-01	METALLIC CABINET	
203	3D		A10-4367-01	CHASSIS	
204	3C		A21-3531-02	DRESSING PANEL	
205	3C		A21-3533-02	DRESSING PANEL	
206	2C		A22-2239-12	SUB PANEL	
207	3C		A64-2002-01	PANEL	
208	3D		B58-1275-04	CAUTION CARD	
-			B46-0100-50	WARRANTY CARD	E1
-			B46-0182-14	ID CARD	
-			B58-1236-04	CAUTION CARD	
-			B58-1285-04	CAUTION CARD	K1M1
-			B58-1289-04	CAUTION CARD	E1
-		*	B64-1569-00	INSTRUCTION MANUAL E,F,S,P	K1
-		*	B64-1572-00	INSTRUCTION MANUAL E,T	M1
-		*	B64-1575-00	INSTRUCTION MANUAL E,R,O	E1
-		*	B64-1576-00	INSTRUCTION MANUAL Z,H,C	E1
-		*	B64-1579-00	INSTRUCTION MANUAL G,D,I	E
210	3D		D10-4204-03	ARM	
211	1C		D10-4033-14	LEVER	
212	1D		D39-0226-03	DAMPER	
213	1C		E30-4138-05	CORD WITH PLUG	
215	1C		F19-1303-04	BLIND PLATE	
-			H02-0813-13	INNER CARTON CASE	
-			H10-4554-12	POLYSTYRENE FOAMED FIXTURE	
-			H25-0337-04	PROTECTION BAG (180X300X0.03)	
-			H25-1115-04	PROTECTION BAG	
-		*	H54-1696-04	ITEM CARTON CASE	K1M1
-		*	H54-1700-04	ITEM CARTON CASE	E1
217	1C		J19-4687-32	HOLDER ASSY	
218L	1C		J19-4713-13	BRACKET	
218R	1C		J19-4715-13	BRACKET	
219	1C		J21-7618-14	MOUNTING HARDWARE ASSY	M1
220	1C		J69-0506-04	ADHESIVE TAPE M1	
222	1C		J99-0604-21	TRAY	
223	2C		K24-1792-04	KNOB	
224	1C		N99-1628-15	SCREW SET	M1
224	1C		N99-1645-15	SCREW SET	K1E1
A	3D		N09-4186-25	STEPPED SCREW	
B	2D		N89-2004-46	BINDING HEAD TAPTITE SCREW	
C	3D		N89-2606-45	BINDING HEAD TAPTITE SCREW	
ME1	2D	*	X92-3640-00	MECHANISM ASSY	
SUB CIRCUIT UNIT (X13-9000-00)					
CN1		*	E40-9555-05	FLAT CABLE CONNECTOR	
J1		*	E56-0825-05	CYLINDRICAL RECEPTACLE	
SUB CIRCUIT UNIT (X13-9730-00)					
CN1			E40-9487-05	FLAT CABLE CONNECTOR	
CN2			E40-9536-05	FLAT CABLE CONNECTOR	

Ref.No.	A d d	N e w	Parts No.	Description	Dest inati on
S1 ,2			S74-0811-05	MICRO SWITCH	
CD PLAYER UNIT (X32-4660-00)					
C2			C92-0628-05	CHIP-TAN 10UF 10WV	
C3			CK73FB1H682K	CHIP C 6800PF K	
C4			CK73FB1H153K	CHIP C 0.015UF K	
C5			CC73FCH1H820J	CHIP C 82PF J	
C6			CC73FCH1H151J	CHIP C 150PF J	
C7			CC73FCH1H040C	CHIP C 4.0PF C	
C8			CC73FCH1H220J	CHIP C 22PF J	
C9			CK73FB1A105K	CHIP C 1.0UF K	
C10			CK73FB1H222K	CHIP C 2200PF K	
C11			CK73FB1H472K	CHIP C 4700PF K	
C12			CK73FB1H103K	CHIP C 0.010UF K	
C13 -16			CK73FB1C104K	CHIP C 0.10UF K	
C17			C92-1463-05	TANTALUM CAPACITOR	
C19			C92-1463-05	TANTALUM CAPACITOR	
C21			CK73FB1H821K	CHIP C 820PF K	
C23			CK73EB1A475K	CHIP C 4.7UF K	
C24			CK73FB1H102K	CHIP C 1000PF K	
C34			C92-0628-05	CHIP-TAN 10UF 10WV	
C46 ,47			C92-1393-05	ELECTRO 10UF 16WV	
C48 ,49			CK73FB1H821K	CHIP C 820PF K	
C52			CK73EB1A475K	CHIP C 4.7UF K	
C55			C92-0628-05	CHIP-TAN 10UF 10WV	
C56			CK73EB1A475K	CHIP C 4.7UF K	
C59			C92-1390-05	ELECTRO 100UF 6.3WV	
C60			CK73EB1A475K	CHIP C 4.7UF K	
C61			CK73FB1C104K	CHIP C 0.10UF K	
C62			C92-1392-05	ELECTRO 100UF 10WV	
C63			CK73EB1A475K	CHIP C 4.7UF K	
C64			C92-1388-05	ELECTRO 470UF 16WV	
C66			CK73EB1C105K	CHIP C 1.0UF K	
C67 -69			CK73FB1C104K	CHIP C 0.10UF K	
C70			CC73FCH1H101J	CHIP C 100PF J	
C71			C92-0628-05	CHIP-TAN 10UF 10WV	
C72			C92-1463-05	TANTALUM CAPACITOR	
C73			CK73FB1C104K	CHIP C 0.10UF K	
C85			C92-0628-05	CHIP-TAN 10UF 10WV	
C180-184			CK73FB1C104K	CHIP C 0.10UF K	
C190			CK73FB1H821K	CHIP C 820PF K	
C192			CK73FB1C334K	CHIP C 0.33UF K	
C193			CK73FB1A684K	CHIP C 0.68UF K	
C194			CK73FB1C104K	CHIP C 0.10UF K	
C200-205			CK73FB1C104K	CHIP C 0.10UF K	
C206			CK73EB1H104K	CHIP C 0.10UF K	
C300			C92-0712-05	TANTALUM CAPACITOR	
C301			CK73FB1C104K	CHIP C 0.10UF K	
CN1			E40-9338-05	FLAT CABLE CONNECTOR	
CN2			E40-9404-05	FLAT CABLE CONNECTOR	
L1			L40-1001-78	SMALL FIXED INDUCTOR(10UH)	
L2			L92-0322-05	CHIP FERRITE	
X1			L78-0596-05	RESONATOR	
X2			L78-0568-05	RESONATOR	

K1: USA M1: Other Areas E1: Europe (KDC-C665Y)

△ indicates safety critical components.

KDC-C665/Y

PARTS LIST

* New Parts

Parts without Parts No. are not supplied.

Les articles non mentionnes dans le Parts No. ne sont pas fournis.

Teile ohne Parts No. werden nicht geliefert.

CD PLAYER UNIT(X32-4660-00)

Ref.No.	A d d	N e w	Parts No.	Description	Dest inati on
CP1			R90-0720-05	MULTI-COMP 100K X4	
CP3			R90-0720-05	MULTI-COMP 100K X4	
CP5 ,6			R90-1014-05	MULTI-COMP 100 X4	
CP7 ,8			R90-0720-05	MULTI-COMP 100K X4	
CP9			R90-0725-05	MULTI-COMP 1K X2	
CP10-12			R90-1014-05	MULTI-COMP 100 X4	
CP14,15			R90-0720-05	MULTI-COMP 100K X4	
CP16			R90-0724-05	MULTI-COMP 1K X4	
CP17			R90-0720-05	MULTI-COMP 100K X4	
R1 -3			RK73FB2A163J	CHIP R 16K J 1/10W	
R4			RK73FB2A391J	CHIP R 390 J 1/10W	
R5			RK73FB2A393J	CHIP R 39K J 1/10W	
R6			RK73FB2A163J	CHIP R 16K J 1/10W	
R7			RK73FB2A393J	CHIP R 39K J 1/10W	
R8			RK73EB2B100J	CHIP R 10 J 1/8W	
R9 ,10			RK73FB2A105J	CHIP R 1.0M J 1/10W	
R15			RK73FB2A104J	CHIP R 100K J 1/10W	
R16			RK73FB2A152J	CHIP R 1.5K J 1/10W	
R18			RK73FB2A103J	CHIP R 10K J 1/10W	
R19			RK73FB2A333J	CHIP R 33K J 1/10W	
R20			RK73FB2A104J	CHIP R 100K J 1/10W	
R21			RK73FB2A103J	CHIP R 10K J 1/10W	
R22			RK73FB2A562J	CHIP R 5.6K J 1/10W	
R25			RK73FB2A113J	CHIP R 11K J 1/10W	
R26			RK73EB2B123J	CHIP R 12K J 1/8W	
R32			RK73FB2A104J	CHIP R 100K J 1/10W	
R50			RK73EB2B103J	CHIP R 10K J 1/8W	
R53 ,54			RK73FB2A681J	CHIP R 680 J 1/10W	
R57 ,58			RK73FB2A223J	CHIP R 22K J 1/10W	
R60 ,61			RK73EB2B101J	CHIP R 100 J 1/8W	
R67			RK73FB2A124J	CHIP R 120K J 1/10W	
R68			RK73EB2B124J	CHIP R 120K J 1/8W	
R69 ,70			RK73FB2A303J	CHIP R 30K J 1/10W	
R71			RK73FB2A912J	CHIP R 9.1K J 1/10W	
R72 ,73			RK73FB2A101J	CHIP R 100 J 1/10W	
R74 ,75			RK73FB2A223J	CHIP R 22K J 1/10W	
R76			RK73FB2A104J	CHIP R 100K J 1/10W	
R77			RK73FB2A183J	CHIP R 18K J 1/10W	
R78			RK73FB2A104J	CHIP R 100K J 1/10W	
R79			RK73FB2A332J	CHIP R 3.3K J 1/10W	
R80			RK73FB2A102J	CHIP R 1.0K J 1/10W	
R81			RK73FB2A103J	CHIP R 10K J 1/10W	
R82			RK73FB2A102J	CHIP R 1.0K J 1/10W	
R83			RK73EB2B102J	CHIP R 1.0K J 1/8W	
R84			RK73FB2A102J	CHIP R 1.0K J 1/10W	
R85 -87			RK73FB2A104J	CHIP R 100K J 1/10W	
R93			RK73EB2B224J	CHIP R 220K J 1/8W	
R95			RK73EB2B104J	CHIP R 100K J 1/8W	
R96			RK73FB2A104J	CHIP R 100K J 1/10W	
R97 ,98			RK73FB2A103J	CHIP R 10K J 1/10W	
R99			RK73FB2A104J	CHIP R 100K J 1/10W	
R100,101			RK73FB2A102J	CHIP R 1.0K J 1/10W	
R102			RK73FB2A104J	CHIP R 100K J 1/10W	
R105,106			RK73FB2A102J	CHIP R 1.0K J 1/10W	
R107			RK73FB2A101J	CHIP R 100 J 1/10W	

Ref.No.	A d d	N e w	Parts No.	Description	Dest inati on
R108			RK73FB2A104J	CHIP R 100K J 1/10W	
R110-113			RK73FB2A104J	CHIP R 100K J 1/10W	
R121			RK73FB2A103J	CHIP R 10K J 1/10W	
R122,123			RK73FB2A102J	CHIP R 1.0K J 1/10W	
R124			RK73FB2A103J	CHIP R 10K J 1/10W	
R126			RK73FB2A104J	CHIP R 100K J 1/10W	
R129			RK73EB2B102J	CHIP R 1.0K J 1/8W	
R134			RK73FB2A104J	CHIP R 100K J 1/10W	
R135-138			RK73FB2A101J	CHIP R 100 J 1/10W	
R139-143			RK73FB2A104J	CHIP R 100K J 1/10W	
R148,149			RK73FB2A101J	CHIP R 100 J 1/10W	
R150			RK73FB2A102J	CHIP R 1.0K J 1/10W	
R151			RK73FB2A471J	CHIP R 470 J 1/10W	
R152			RK73FB2A623J	CHIP R 62K J 1/10W	
R153,154			RK73FB2A472J	CHIP R 4.7K J 1/10W	
R155,156			RK73FB2A101J	CHIP R 100 J 1/10W	
R161			RK73FB2A163J	CHIP R 16K J 1/10W	
R162			RK73FB2A472J	CHIP R 4.7K J 1/10W	
R180-184			RK73FB2A100J	CHIP R 10 J 1/10W	
R190			RK73FB2A472J	CHIP R 4.7K J 1/10W	
R191			RK73FB2A123J	CHIP R 12K J 1/10W	
R192,193			RK73FB2A683J	CHIP R 68K J 1/10W	
R194			RK73FB2A224J	CHIP R 220K J 1/10W	
R201			RK73FB2A104J	CHIP R 100K J 1/10W	
R202,203			RK73FB2A103J	CHIP R 10K J 1/10W	
R205,206			RK73EB2B102J	CHIP R 1.0K J 1/8W	
W5 -7			R92-2052-05	CHIP R 0 J 1/10W	
W9 ,10			R92-2053-05	CHIP R 0 J 1/8W	
S1			S68-0823-05	PUSH SWITCH	
S2			S70-0838-05	TACT SWITCH	
S3			S68-0823-05	PUSH SWITCH	
S4			S62-0863-05	SLIDE SWITCH	
D1			DAP202K	DIODE	
D3 ,4			MA3056-M	ZENER DIODE	
D5			MAZ90750M	ZENER DIODE	
D7			MA3056-M	ZENER DIODE	
D8			MAZ90620M	ZENER DIODE	
D9 ,10			M1F60	DIODE	
D11			1SR154-400	DIODE	
D12			DA204K	DIODE	
D13			DAN202U	DIODE	
D14			MAZ90910M	ZENER DIODE	
D15			DAP202K	DIODE	
D16			DAP202U	DIODE	
D20			DAN202U	DIODE	
D21 ,22			DAN202K	DIODE	
D23 ,24			DAN202U	DIODE	
IC1			UPD637116C	MOS-IC	
IC4			KIA78L05F	ANALOGUE IC	
IC5			LA6556	ANALOGUE IC	
IC7			UPD784214GC062	MI-COM IC	
IC8			S-24C01B	MEMORY IC	
IC9			S-80830ANNP	MOS-IC	
IC11			LC3564BT-70	MEMORY IC	

K1: USA M1: Other Areas E1: Europe (KDC-C665Y)

⚠ indicates safety critical components.

PARTS LIST

* New Parts

Parts without Parts No. are not supplied.

Les articles non mentionnes dans le Parts No. ne sont pas fournis.

Teile ohne Parts No. werden nicht geliefert.

CD PLAYER UNIT(X32-4660-00)
MECHANISM ASSY(X92-3640-00)

Ref.No.	A d d	N e w	Parts No.	Description	Dest inati on
Q1			MCH6101	TRANSISTOR	
Q4			DTA124EK	DIGITAL TRANSISTOR	
Q5			DTA124EUA	DIGITAL TRANSISTOR	
Q6 ,7			DTC343TK	DIGITAL TRANSISTOR	
Q8			DTA124EK	DIGITAL TRANSISTOR	
Q9			2SB1202	TRANSISTOR	
Q10			2SB1295	TRANSISTOR	
Q11			DTC124EK	DIGITAL TRANSISTOR	
Q12			DTA124EUA	DIGITAL TRANSISTOR	
Q13			DTC124EUA	DIGITAL TRANSISTOR	
Q14			DTA143EK	DIGITAL TRANSISTOR	
Q16			2SC2412K	TRANSISTOR	
Q17			DTA143EK	DIGITAL TRANSISTOR	
Q18			DTC124EK	DIGITAL TRANSISTOR	
Q19			DTC124EUA	DIGITAL TRANSISTOR	
Q20			DTC124EK	DIGITAL TRANSISTOR	
Q21			2SB1202	TRANSISTOR	
Q22			2SC2412K	TRANSISTOR	
Q31			DTC124EUA	DIGITAL TRANSISTOR	
TH1			NTH5G20B333K07	THERMISTOR	
MECHANISM ASSY (X92-3640-00)					
1	1A		A10-4700-13	CHASSIS ASSY	
2	2B		A10-4231-22	CHASSIS CALKING ASSY	
3	1B		A10-4233-63	CHASSIS CALKING ASSY	
4	2B		A10-4235-84	CHASSIS CALKING ASSY	
5	3B		A10-4248-32	CHASSIS CALKING ASSY	
6	2A		A10-4247-12	CHASSIS	
7	1B		A10-4249-42	CHASSIS CALKING ASSY	
C1			C90-2945-05	ELECTRO 0.047F 5.5WV	
9	2B		D10-4018-23	ARM	
10	1A		D10-4293-03	ARM	
11	3B		D10-4020-33	LEVER	
12	1B		D10-4036-34	ARM	
13	2A		D10-4037-04	SLIDER ASSY	
14	1B		D10-4035-23	SLIDER	
15	3A		D10-4026-03	LEVER	
16	2A		D10-4027-04	LEVER ASSY	
17	3B		D10-4029-04	SLIDER ASSY	
18	2B		D10-4032-13	SLIDER	
19	1B		D10-4138-03	LEVER	
20	2B		D12-0618-13	CAM	
21	1B		D12-0619-33	CAM	
22	1A		D13-1251-14	GEAR	
23	2A		D13-1252-04	GEAR	
24	1A		D13-1253-04	GEAR	
25	2A		D13-1254-04	GEAR	
26	2B		D13-1255-24	GEAR	
27	2B		D13-1256-04	GEAR	
28	1A		D13-1257-14	GEAR ASSY	
29	2A		D13-1259-04	GEAR	
30	2B		D13-1262-34	GEAR	
31	3A		D13-1263-04	WORM	
32	3A		D13-1264-04	GEAR	
33	3A		D13-1265-04	GEAR	

Ref.No.	A d d	N e w	Parts No.	Description	Dest inati on
34	2B		D13-1266-04	GEAR	
35	2B		D13-1338-04	GEAR	
36	2A		D19-0614-24	LEAD SCREW	
37	2B		D19-0615-14	CLUTCH ASSY	
41	3B		D39-0225-05	DAMPER	
FC1	3B		E39-0172-15	FLAT CABLE	
FC2	3B		E39-0173-15	FLAT CABLE	
43	2A		F09-1220-04	SHEET	
44	3B		F09-1245-04	SHEET	
45	2B		G01-2778-04	TORSION COIL SPRING	
46	2B		G01-2779-04	TORSION COIL SPRING	
47	2A		G01-2781-04	COMPRESSION SPRING	
48	3B		G01-2782-14	TORSION COIL SPRING	
49	1B		G01-2783-14	EXTENSION SPRING	
50	3A		G01-2784-04	EXTENSION SPRING	
51	3A		G01-2785-04	EXTENSION SPRING	
52	1B		G01-2789-14	EXTENSION SPRING	
53	2A		G01-2810-04	EXTENSION SPRING	
54	3B		G01-2809-14	EXTENSION SPRING	
55	1B		G01-2814-24	TORSION COIL SPRING	
57	2A		G02-1235-24	FLAT SPRING	
58	2A		G02-1256-14	FLAT SPRING	
59	2B		G02-1237-13	FLAT SPRING	
60	2B		G02-1238-34	FLAT SPRING	
62	3A		G02-1240-04	FLAT SPRING	
64	2B		G10-1023-04	FELT	
65	2B		J11-0614-03	CLAMPER	
66	2A		J21-7695-04	MOUNTING HARDWARE	
67	3B		J21-7696-23	MOUNTING HARDWARE	
68	3A		J21-7698-14	MOUNTING HARDWARE	
69	1B		J21-7767-13	MOUNTING HARDWARE	
71	2B		J90-0777-23	GUIDE	
72	2B		J90-0759-03	GUIDE	
73	2B		J90-0760-03	RAIL	
FPC1	2A		J84-0099-05	FLEXIBLE PRINTED WIRING BOARD	
A	1B		N09-4126-05	MACHINE SCREW (2X3.5C)	
B	3B		N09-4288-05	TAPTITE SCREW (2X2.5 S)	
C	3A		N86-2005-46	BINDING HEAD TAPTITE SCREW	
D	2B		N09-4189-05	TAPTITE SCREW (1.7X1.5(S))	
E	2A		N09-4154-05	TAPTITE SCREW	
F	1A		N09-4181-05	MACHINE SCREW (M1.7X3)	
G	2A		N39-1722-46	PAN HEAD MACHIN SCREW	
J	2B		N19-2105-14	FLAT WASHER	
K	2B		N19-2058-04	FLAT WASHER	
L	1B		N19-2080-14	FLAT WASHER	
M	1A		N19-2028-04	FLAT WASHER	
75	3B		R33-0201-05	SLIDE TYPE VARIABLE RESISTOR	
M1	2A		T42-0797-04	MOTOR ASSY	
M2,3	3A		T42-0788-05	DC MOTOR	
PU1	2A		T25-0216-05	OPTICAL PICKUP HEAD	
Q15			2SB1565(E,F)	TRANSISTOR	

K1: USA **M1:** Other Areas **E1:** Europe (KDC-C665Y)

⚠ indicates safety critical components.

SPECIFICATIONS

CD section

Laser Diode	GaAIAs ($\lambda=780$ nm)
Digital Filter	8 Times Over Sampling
D/A Converter	1 Bit
Spindle Speed	500 ~ 200 rpm (CLV)
Wow & Flutter	Below Measurable Limit
Frequency Response	5Hz~20kHz (± 1 dB)
Total Harmonic Distortion	0.005% (1kHz)
S/N Ratio (dB)	100dB
Dynamic Range	94dB
Channel Separation	96dB

General

Operating Voltage	14.4 V (11~16V allowable)
Current Consumption	0.8A at rated power
Installation Size (W \times H \times D)	250 \times 64 \times 176mm (9-13/16 \times 2-1/2 \times 6-13/16 in.)
Weight	1.8 kg (4.0 LBS)

Note:

KENWOOD follows a policy continuous advancements in development.
For this reason specifications may be changed without notice.

KENWOOD CORPORATION

14-6, Dogenzaka 1-chome, Shibuya-ku, Tokyo 150-8501, Japan

KENWOOD SERVICE CORPORATION

P.O. Box 22745, 2201 East Dominguez Street,
Long Beach, CA90801-5745, U.S.A.

KENWOOD ELECTRONICS CANADA INC.

6070 Kestrel Road, Mississauga, Ontario, Canada L5T 1S8

KENWOOD ELECTRONICS LATIN AMERICA S.A.

P.O. Box 55-2791, Piso 6, Plaza Chase, Cl. 47 y,
Aquilino de la Guardia, Panama, Republic of Panama

KENWOOD ELECTRONICS BRASIL LTDA.

Av. Moema, 170-17°, Andar-Cobertura "B",
Ed. Maximum Service Center, 04077-020 Moema,
São Paulo-SP-Brasil

KENWOOD ELECTRONICS UK LIMITED

Kenwood House, Dwight Road, Watford, Herts,
WD1 8EB United Kingdom

KENWOOD ELECTRONICS DEUTSCHLAND GMBH

Rembrücker-Str. 15, 63150 Heusenstamm, Germany

KENWOOD ELECTRONICS FRANCE S.A.

13, Boulevard Ney, 75018 Paris, France

KENWOOD ELECTRONICS BELGIUM N.V.

Mechelsesteenweg 418, B-1930 Zaventem, Belgium

KENWOOD ELECTRONICS ITALIA S.p.A.

Via G. Sirtori 7/9, 20129 Milano, Italy

KENWOOD IBÉRICA S.A.

Bolivia, 239-08020 Barcelona, Spain

KENWOOD ELECTRONICS AUSTRALIA PTY. LTD.

(A.C.N. 001 499 074)

16 Giffnock Avenue, North Ryde, N.S.W. 2113, Australia

KENWOOD ELECTRONICS (HONG KONG) LTD.

Unit 3712-3724, Level 37, Tower 1, Metroplaza,
223 Hing Fong Road, Kwai Fong, N.T., Hong Kong

KENWOOD ELECTRONICS GULF FZE

P.O. Box 61318, Jebel Ali, Dubai, U.A.E.

KENWOOD ELECTRONICS (THAILAND) CO., LTD.

2019 New Pechburi Road, Bangkapi, Huaykwang,
Bangkok, 10320 Thailand

KENWOOD ELECTRONICS SINGAPORE PTE. LTD.

1 Genting Lane, #07-00, Kenwood Building, Singapore 349544

KENWOOD ELECTRONICS (MALAYSIA) SDN BHD

#4.01 Level 4, Wisma Academy Lot 4A, Jalan 19/1,
46300 Petaling Jaya, Selangor Darul Ehsan, Malaysia